

## RI60176E

### 60V Brushless 1" Extended Anvil Jumbo Impact Wrench



- Network Rail pads approved - Catalogue 0039/127078
- Long 6" anvil length ensuring accessibility to get hard to reach places with extreme torque
- World's most powerful battery-powered impact wrench for Pneumatic replacement-free from compressor & hoses
- Removable & adjustable side handle
- Parallel battery system for double capacity & run-time
- Auto shut-off for 4 different torque settings



### TECHNICAL SPECIFICATIONS

Voltage	60V
Drive Size	6" Square
Max. Tightening Torque	340 / 680 / 1,080 / 1,690 / 3,000 Nm
Max. Reverse Torque	4,067 Nm
No Load Speed	0 - 1,200 RPM
Impacts per Minute	0 - 1,450 IPM
Tool Weight (w/o battery)	11.1 kg

### TECHNOLOGIES



Electronic Torque Control uses our advanced tightening technology to automatically shut off when the correct torque has been achieved. Different models will have alternative different stages to customize your workflow to optimize to the correct workload.



Our Patented all-in-one motor integrates multiple components into a single unit, reducing size and complexity while improving efficiency and reliability



DC motors have traditionally been driven by carbon brushes to power the motor. Over time these wear out and need replacing. All our motors are brushless meaning that the motor is controlled electronically without the need for carbon brushes ensuring your tool is maintenance-free.

## DIMENSIONAL DRAWING

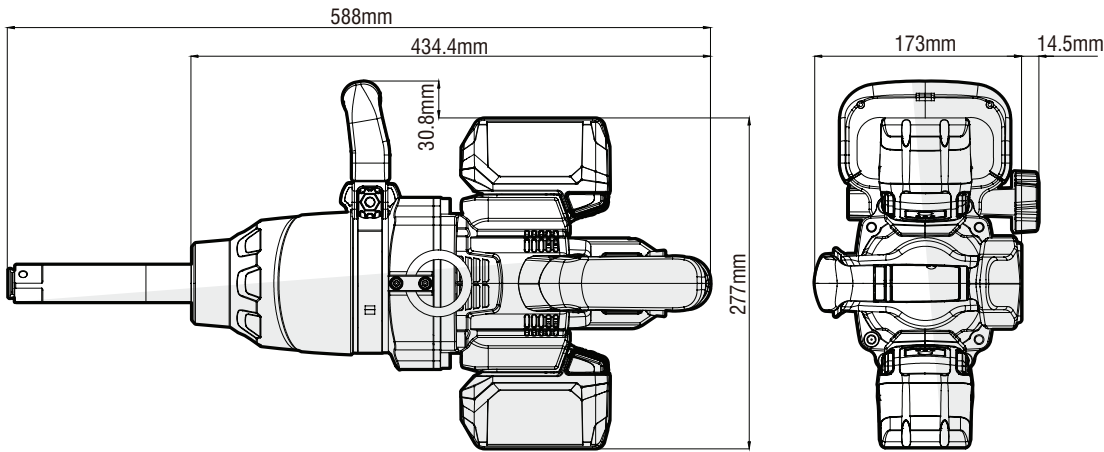

## TOOL FEATURES



This power tool delivers exceptional torque, tackling heavy-duty tasks with ease and reliability.



An impact wrench uses a hammer and anvil to generate torque. The hammer's rapid, powerful blows tighten or untighten, reducing the operator's torque reaction.



The IP54 rating ensures this power tool is protected against dust and water splashes, providing durability and reliability in various working environments.



Illuminate your workspace with the built-in LED light on this power tool, ensuring visibility in low-light conditions for enhanced work safety.



The auto shut-off function automatically shuts down the tool to prevent over-tightening and enhance safety during operation.



This power tool utilizes parallel batteries for doubling runtime. Able to operate using one battery.